

73752
Frame Bracket Kit for DSP
24" DP FW & GN Hitches

IMPORTANT: The bracket/hole placement is a suggestion. Frames vary! Always check the frame prior to drilling if this is the best location for the brackets. If the suggested holes are not ideal, move to the next closest hole.			Measurement end of rail to end of box			Frame Bracket placement by hole number (see drawing below)
			Comp. box 6.2'	Short box 6.5'	Long box 8'	
Hitch application	Notes	Years	see notes	18.75" ²	21.5" ²	FL605/FR605 - 3, 4 & 6
Dodge	ALL	2011-2012	see notes	18.75" ²	21.5" ²	FL605/FR605 - 3, 4 & 6
Dodge 1500/2500	Uni-Tube Frame, Leaf Springs	2013	see notes	18.75" ²	21.5" ²	FL605/FR605 - 3, 4 & 6
Dodge 1500	Air Ride Suspension, Leaf Springs	2014-cur	see notes	18.75" ²	21.5" ²	FL605/FR605 - 3, 4 & 6

NOTE #1: Can be installed on compact box. Must be used with 10" King Pin extension or with the Reese Sidewinder use the RBW Wedge.
 NOTE #2: Place center of king pin 1"-2" ahead of the axle when in travel position (closest to cab).

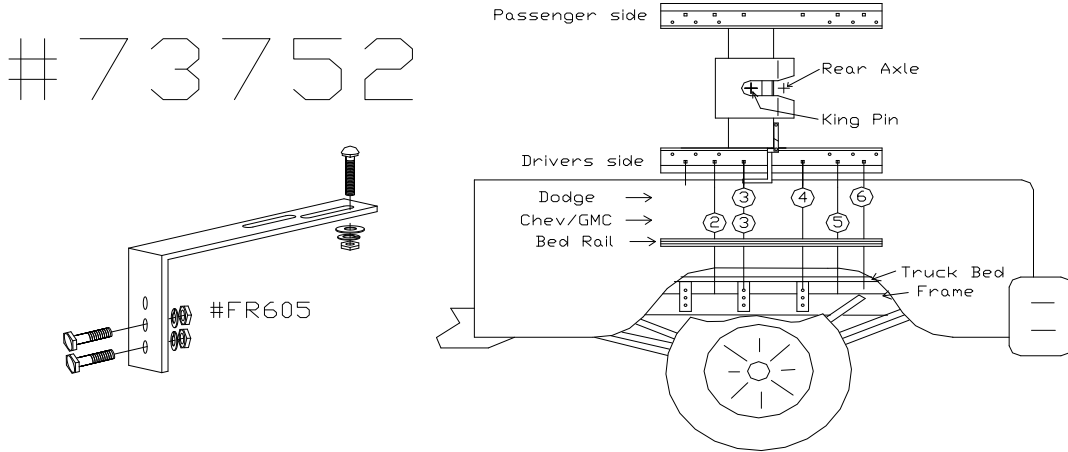

NOTE: Brackets may have the oblong hole in center only, making them universal and NOT side specific.

*** At any point during installation, ensure that once placement is made, there are NO lines or wires interfering prior to drilling.**

Parts List		Contents of Bolt Pack # 73745/B		Tools Required	
3	FL605 Frame Bracket	1	Bolt Leaders 48"	3/4"	Wrench and Socket
3	FR605 Frame Bracket	6	Carriage Bolt 1/2 x 3, Grade 5, UNC, Plated	100 FT	Torque Wrench
1	Bolt Pack 73745/B	6	Flat Washer 1/2, Plated	Drill and 1/2"	Drill Bit
1	Instructions F70000 Series	12	Hex Bolt 1/2 x 1-1/2, Grade 5, UNC, Plated		
		18	Hex Nut 1/2, Grade 5, UNC, Plated		
		18	Lock Washer 1/2, Grade 5, Plated		
Shipping weight:	26 lbs / 11.8 kg				

Bed Rail Placement: 1) Follow the general installation guidelines for the assembly of the upper half of hitch system of your choice that is included with the system. The rails have a closed end and an open end (to slide the hitch in and out). Place closed end near cab. Slide the hitch into rails and lock in travel position (closest to end of the rail near cab). Place system with rails in the truck box and use measurements above as a guideline. Center hitch in between wheel wells. This installation recommends the use of a set of two (2) bed rail rib spacers #73551P. Rib spacers keep the rail level during installation and usage of the hitch. Place rib spacers between box and rails. **Note:** For best results for the installation of gooseneck hitches, install or use a fifth wheel hitch as a template or refer to the measurements under general "Gooseneck Hitch" installation guidelines.

Bed Rail Mounting: Centre the rails in the bed of the truck box with the measurements listed on the information chart above for long, short or compact boxes. From side to side using the rails as a template, *drill holes as indicated above through the floor of the truck bed then drop the 1/2" x 3" carriage bolts into the holes.

Frame Bracket Placement and Mounting: Place the supplied brackets upon the bolts that were installed in the box in step 2. Note some brackets may be easier to place than others depending on their locations.

Once brackets are installed in the order they fit best, tighten all brackets to the box using the supplied fasteners. Once they are tightened, *drill holes using the bracket as a template. Make sure there are no lines or wires interfering during *drilling. After *drilling is complete install the 1/2"x1-1/2" Hex Bolts to secure the brackets to the frame rails.

Tighten all mounting fasteners to the correct torque specifications listed below.

Bolt Size	Grade 5 Torque	Metric	Grade 8.8 Torque
9/16	110 Ft. Lb	8 mm	18 Ft. Lb.
7/16	54 Ft. Lb	10 mm	36 Ft. Lb.
1/2	72 Ft. Lb.	12 mm	75 Ft. Lb.
5/8	150 Ft. Lb	14 mm	103 Ft. Lb.
3/4	245 Ft. Lb	Maximum torque for weld or weld nuts is 38 FT/Lb	

Warning: Check Fasteners annually or before usage, if the hitch is damaged replacement may be necessary
 Do Not exceed hitch manufactures hitch ratings listed above, DO NOT drill or alter this product. This product is only intended for the application listed above, see vehicle owner's manual for maximum towing capacity (GVWR). This product is intended for usage with the correct towing accessories and not to be used with tow ropes, cables, chains or any type of stretch or elastic rope.

DSP Hitches are manufactured by 2114391 Alberta Ltd. Edmonton Alberta, Canada
 For more information on DSP Hitches call 1-800-265-3377 or visit us at www.dsphitches.com